

NEW

FILLING NOZZLE

– STERILISABLE BY GAMMA IRRADIATION OR AUTOCLAVING

- Available in 7 different inner diameters from Ø0.6 to Ø8.0
- Length allows for bottom-up filling applications
- Surface finish at tip of nozzle prevents dripping
- Meets FDA and USP class VI requirements
- Supplied in Tyvek pouch ready for autoclaving or gamma irradiation
- Packed in ISO Class 8 clean room
- Full material traceability
- Batch specific quality certificate included
- Designed for fast change-over
- Fits standard nozzle holders on Watson-Marlow Flexicon filling machines

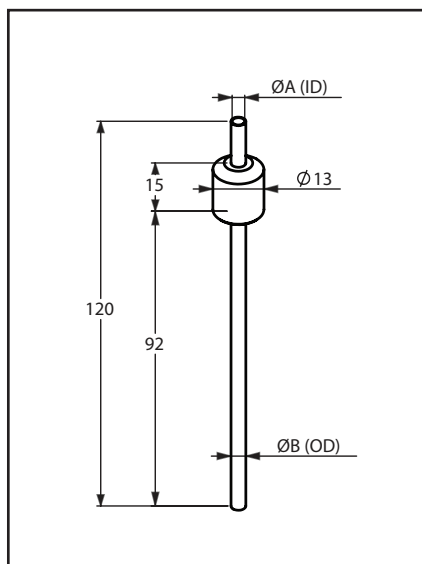

SPECIFICATIONS				
Materials	AISI 316L and PEEK			
	A (ID)	B(OD)	Fill volumes from	Part number
Dimensions in mm	Ø0,6	Ø1,0	0.1 ml	30-040-006
	Ø1,0	Ø1,5	0.5 ml	30-040-010
	Ø1,6	Ø2,1	1.7 ml	30-040-016
	Ø3,2	Ø3,8	6.5 ml	30-040-032
	Ø4,5	Ø5,5	12.0 ml	30-040-045
	Ø6,0	Ø7,0	22.0 ml	30-040-060
	Ø8,0	Ø9,0	35.0 ml	30-040-080
Nozzle holder incl. arm for filling stand				30-700-053
Compliance	FDA USP 31, class VI FDA 21 CFR Part 177.2415, 2008 BSE/TSE free			
Quality certificate	Included			



FILLING NOZZLE

– STAINLESS STEEL AISI316L

- Filling from 0.1 ml to 250 ml
- Fits nozzle holders for FF20, FF30, FPC50, FP50 and FMB210
- Can be applied together with gas filling nozzle 30-031-xxx

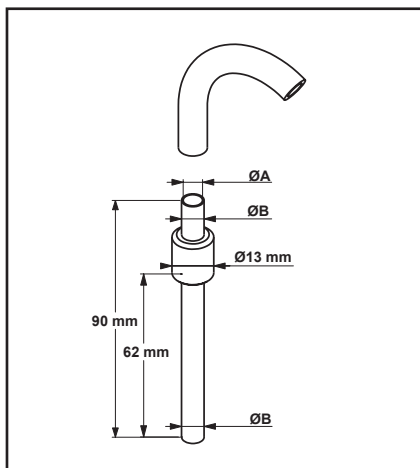

SPECIFICATIONS				
Materials	AISI 316L			
	A (ID)	B(OD)	Fill volumes from	Part number
Dimensions in mm*	Ø0,6	Ø1,0	0.1 ml	30-030-006
	Ø1,0	Ø1,5	0.5 ml	30-030-010
	Ø1,6	Ø2,1	1.7 ml	30-030-016
	Ø3,2	Ø3,8	6.5 ml	30-030-032
	Ø4,5	Ø5,5	12.0 ml	30-030-045
	Ø6,0	Ø7,0	22.0 ml	30-030-060
	Ø8,0	Ø9,0	35.0 ml	30-030-080
Set of all sizes				82-100-010
Nozzle holder incl. arm for filling stand				30-700-053
Declaration of compliance - Type 2.1 according to DS/EN 10204				Included

*Tolerances according to DS/ISO 2768-1-m

FILLING NOZZLE

– GAS PURGING AROUND FILLING NOZZLE

- For gas purging around filling nozzle for liquid
- Protects liquid to be filled from contact with surrounding air
- Can be used together with filling nozzle 30-030-xxx
- Fits nozzle holders for FMB210, FPC50, FP50 and FF20

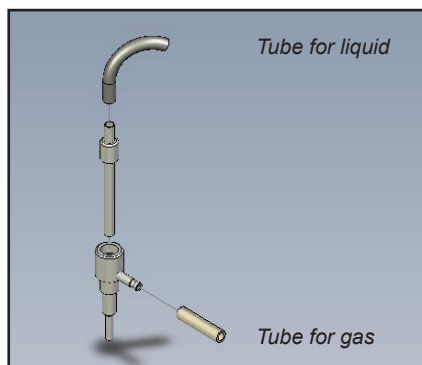

SPECIFICATIONS			
Materials	AISI 316L + Viton		
	C (ID)	D (OD)	Part number
Dimensions in mm	Ø4,5	Ø 5,3	30-031-050
	Ø8,5	Ø10,1	30-031-090
O-ring for gas filling nozzle			54-020-116
Nozzle holder incl. arm for filling stand			30-700-053
Declaration of compliance - Type 2.1 acc.: DS/EN 10204			Included

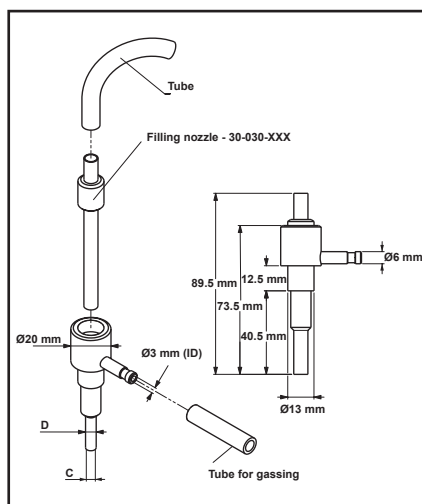

Filling nozzles from the 30-030-xxx series to be applied with gas purging nozzles:

- 0.6 ID up to 3.2 ID filling nozzles can be applied with 30-031-050
- 4.8 ID and 6.0 ID filling nozzles can be used with 30-031-090

FILLING NOZZLE

– HAND-HELD

- Ergonomic design
- For manual movement of filling nozzle
- For filling from 1 ml to 150 ml



SPECIFICATIONS				
Materials	AISI 316L			
	A (ID)	B(OD)	Fill volumes from	Part number
Dimensions in mm	Ø1,3	Ø2,3	1.0 ml	30-015-020
	Ø3,1	Ø4,0	6.5 ml	30-015-040
	Ø4,1	Ø5,0	12.0 ml	30-015-050
	Ø5,1	Ø8,5 & 6,0	22.0 ml	30-015-060
Declaration of compliance - Type 2.1 acc.: DS/EN 10204				Included

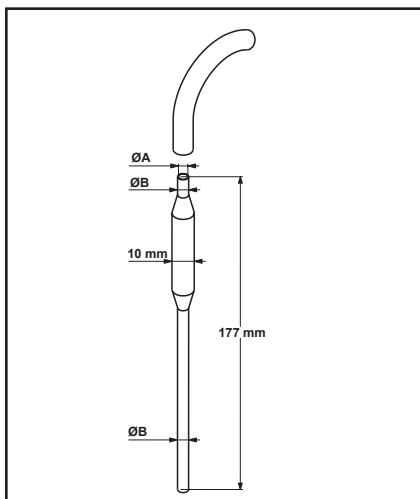

FILLING NOZZLE

– WITH PNEUMATIC VALVE

- Large volume filling
- Viscous liquids and creams
- Bottom-up filling applications
- Prevents after dripping

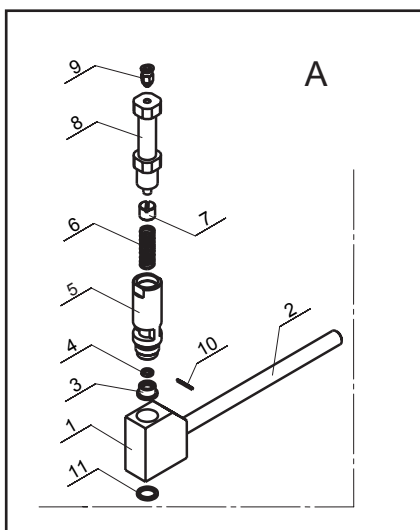
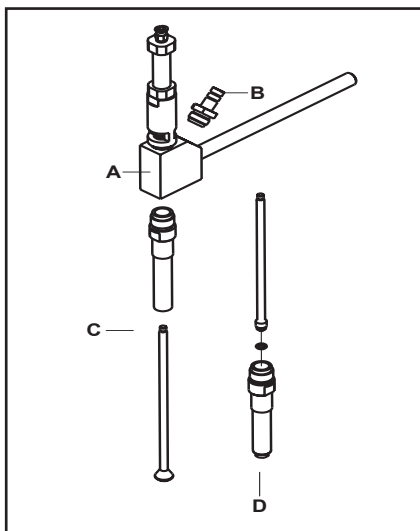

A = NOZZLE BODY			
		To be used with	Part number
A	Incl. pneumatic control box	PD12, PD22, GD30	82-510-000
A1	Excl. pneumatic control box	PF22, DF32, GF30	30-100-000

B = TUBE CONNECTOR			
	ID	OD	Part number
Dimensions in mm	7	10	30-100-105
	10	13	30-100-110

C = FILLING NOZZLE WITH OUTSIDE VALVE				
	ID	OD	Length of nozzle	Part number
Dimensions in mm	8	10	110 / 60	30-100-250
	12	14	110 / 60	30-100-260
	8	10	300 / 250	30-100-270
	12	14	300 / 250	30-100-280

D = FILLING NOZZLE WITH INSIDE VALVE				
	ID	OD	Length of nozzle	Part number
Dimensions in mm	6	14	110 / 63	30-100-208
	7,5	14	110 / 53	30-100-210

SPARE PARTS FOR A / A1		
Pos.	Description	Part number
1	Nozzle body	30-100-005
2	Arm	30-700-050
3	House for gasket	30-100-012
4	Gasket	54-190-060
5	head for cylinder	30-100-010
6	Spring	30-100-015
7	Spring stop	30-100-020
8+9	Pneumatic cylinder	30-100-050
10	Gasket	30-100-053
11	Gasket	30-100-051

- A + B + C/D must be ordered together
- Nozzle length is stated as total length / length to enter into bottle

FILLING NOZZLE

– DISPOSABLE PEI 1000

- For filling from 0.5 ml to 100 ml
- For liquids not to be in contact with metal
- For use in disposable filling assemblies
- Sterilisable by gamma irradiation
- Fits filling nozzle holders on Watson-Marlow Flexicon filling machines. E.g. FF20, FF30, FP50, FPC50 and FMB210

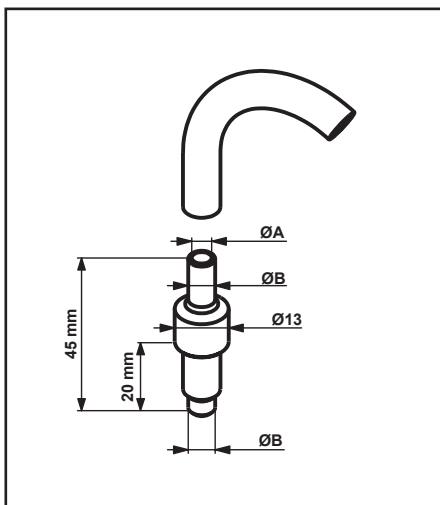
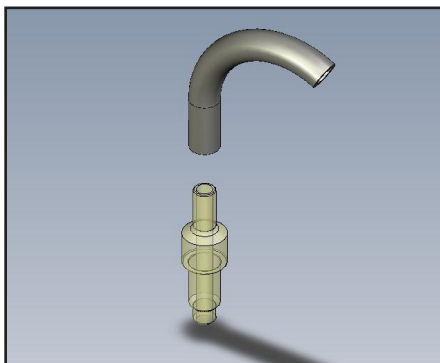

SPECIFICATIONS				
Materials	PEI 1000 (Polyetherimide)			
	A (ID)	B(OD)	Fill volumes from	Part number
Dimensions in mm	0.8	2.2	0.5 ml	30-033-008
	1.2	2.6	1.0 ml	30-033-012
	1.6	3.0	1.7 ml	30-033-016
	3.2	4.6	6.5 ml	30-033-032
	4.8	6.5	12.0 ml	30-033-048
	6.0	8.0	22.0 ml	30-033-060
Nozzle holder incl. arm for filling stand				30-700-053
Compliance			FDA 21 CFR § 177.1595 USP Class VI	
Declaration of compliance - type 2.1 acc.: DS/EN 10204			Included	